

Knowing and Installing Your Optical Digital I/O Card

Introduction

The Optical Digital I/O card is an upgrade for Sound Blaster® Live!™ and Sound Blaster Live! Value. The card provides digital connectors found in professional audio systems and the popular MiniDisc.

Now you can experience the most powerful sound card with a full array of digital connectors specifically designed to deliver the full potential of Environmental Audio™. The Optical Digital I/O coupled with Sound Blaster Live! or Sound Blaster Live! Value will deliver clean digital audio output in both conventional RCA and optical formats catering to the needs of the DAT and the MiniDisc communities.

Checking System Requirements

Your card requires:

- A Sound Blaster Live! or Sound Blaster Live! Value card
- An available bracket

If you have a Sound Blaster Live! Value card, check your card to see whether it has an AUD_EXT (2x20 pin header) connector or a SPDIF_EXT (2x6 pin header) connector:

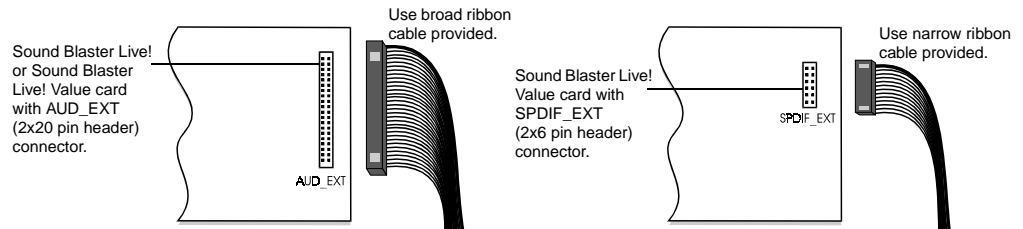

Upgrading Your Sound Blaster Live! or Sound Blaster Live! Value Card

When you upgrade your Sound Blaster Live! or Sound Blaster Live! Value with the Optical Digital I/O card, you will enjoy additional features shown in Table 1.

Table 1: Upgrading Your Sound Blaster Live! or Sound Blaster Live! Value card.

Features	After Upgrading	
	SB Live! or SB Live! Value card with AUD_EXT header	SB Live! Value card with SPDIF_EXT header
SPDIF In	✓ (via DIO)	✓ (via DIO)
SPDIF Out	✓ (via DIO)	✓ (via DIO)
Optical In	✓ (via DIO)	✓ (via DIO)
Optical Out	✓ (via DIO)	✓ (via DIO)
2nd Line In	✓	N.A.
MIDI In	✓	N.A.
MIDI Out	✓	N.A.
Digital DIN	✓	✓
SPDIF RCA Bypass	✓	N.A.
SPDIF Optical Bypass	✓	N.A.

N.A.: Not Applicable

DIO: Digital I/O Module

✓ : Feature is available.

Installing the Optical Digital I/O Card



Make sure there is sufficient space between the Optical Digital I/O card and the adjacent cards such that the cards do not touch.

1. Switch off your system.
2. Touch a metal plate on your system to ground yourself and to discharge any static electricity.
3. Unplug the power cord from the wall outlet and remove the cover from your system.
4. If you have a Sound Blaster Live! card, disconnect any existing Digital I/O card from it.
5. Connect the Optical Digital I/O card to the Sound Blaster Live! or Sound Blaster Live! Value card using the digital I/O cable, as shown in Figure 1.

Note: If your Sound Blaster Live! or Value card has the AUD_EXT (2x20 pin header) connector, use the broader ribbon cable.

If your Sound Blaster Live! Value card has the SPDIF_EXT (2x6 pin header) connector, use the narrow ribbon cable.

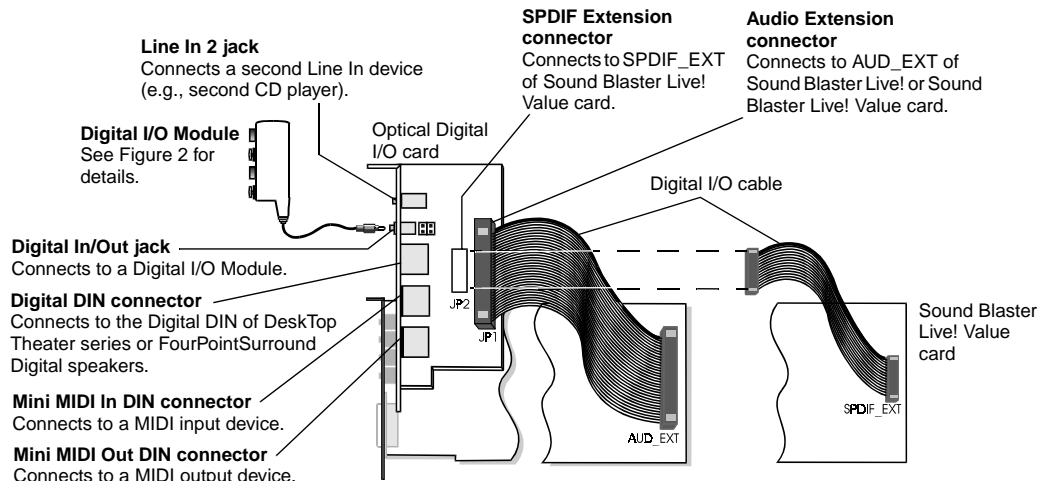

Figure 1: Connecting the Optical Digital I/O card.

6. Remove the metal plate from an unused PCI expansion slot in your system and put the screw aside, to be used later.

7. Place the metal bracket of the Optical Digital I/O card into the unused bracket on the computer casing.
8. Secure the card to the casing with a screw and replace the cover onto your system.
9. Plug the power cord back into the wall outlet and switch on the system.

Your Digital I/O Module



You can route signals from SPDIF In to SPDIF Out through the “SPDIF Bypass” feature (under Digital I/O tabbed page of the Device Controls window in AudioHQ). This feature allows you to share the SPDIF output path through the Digital I/O Module from the audio card OR another SPDIF output device (e.g., DeskTop Theater 5.1 speaker system), without the hassle of plugging in and removing the connection to the single RCA input from either of the two devices.

Your Digital I/O Module has these jacks which allow you to attach other devices:

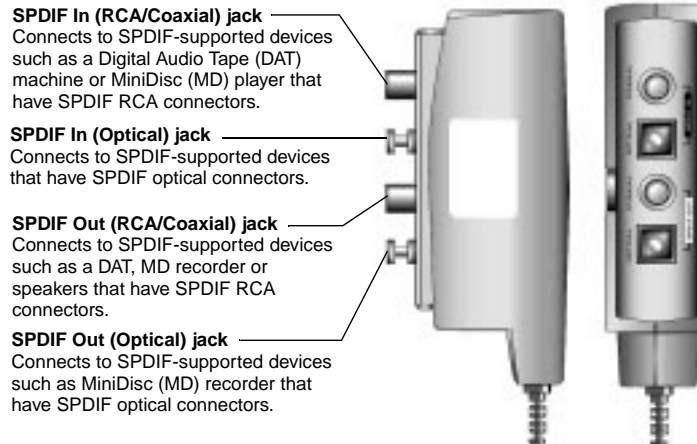

Figure 2: Jacks on the Digital I/O Module.

- ❑ SPDIF recording can be done only through the Optical Digital I/O card, where you connect the Digital I/O Module to the Digital In/Out jack.
- ❑ There can be two simultaneous SPDIF Out connections: one through the coaxial connector, the other through the optical connector. However, only one SPDIF In connection is possible at a time. This means that you can connect to either the SPDIF In (RCA) jack or the SPDIF In (Optical) jack but not both at the same time.

Installing Software in Windows 95/98 and Windows NT 4.0

1. Insert the installation disc into your CD-ROM drive.
2. When a dialog box appears, click the Install button and skip to step 5. If no dialog box appears, click the Start button followed by Run.
3. In the Run dialog box, type
D::\AUDIO*Language*\9XSETUP\SETUP.EXE (for Windows 95/98) **OR**
D::\AUDIO*Language*\NTSETUP\SETUP.EXE (for Windows NT 4.0)
where **D:** represents your CD-ROM drive and *Language* is the language of the software that you want to install.
4. Click the Install button.
5. When prompted to restart the system, click the OK button to complete the installation.

Recommended Connection and Usage Examples

Figure 3 on the following page shows you how to connect to the SB Live! card (with the Optical Digital I/O card and Digital I/O Module) for playing games and music, watching DVD movies and playing DVD games, and for recording and content authoring. The Cambridge SoundWorks FourPointSurround and DeskTop Theater 5.1 speaker systems are used in these examples. The following are some notes regarding these connections:

Playing Games and Music

- Experience crystal clear gaming sequences or music from the Digital DIN connection.

Watching DVD Movies or Playing DVD Games

- If you wish to connect your Encore Dxr2, Encore Dxr3 or MPEG2 decoder card to an external Dolby Digital (AC-3) decoder such as DeskTop Theater speaker systems, disconnect the Sound Blaster Live! card's Aux In connector from the decoder card's Audio Out connector. However, if an external Dolby Digital (AC-3) decoder speaker system is not available, this connection is necessary.

Recording and Content Authoring

- External digital recording can be done via the Digital I/O Module.
- A second analog Line In on the Optical Digital I/O card allows you to connect to another input device (e.g., a portable CD player) for recording.

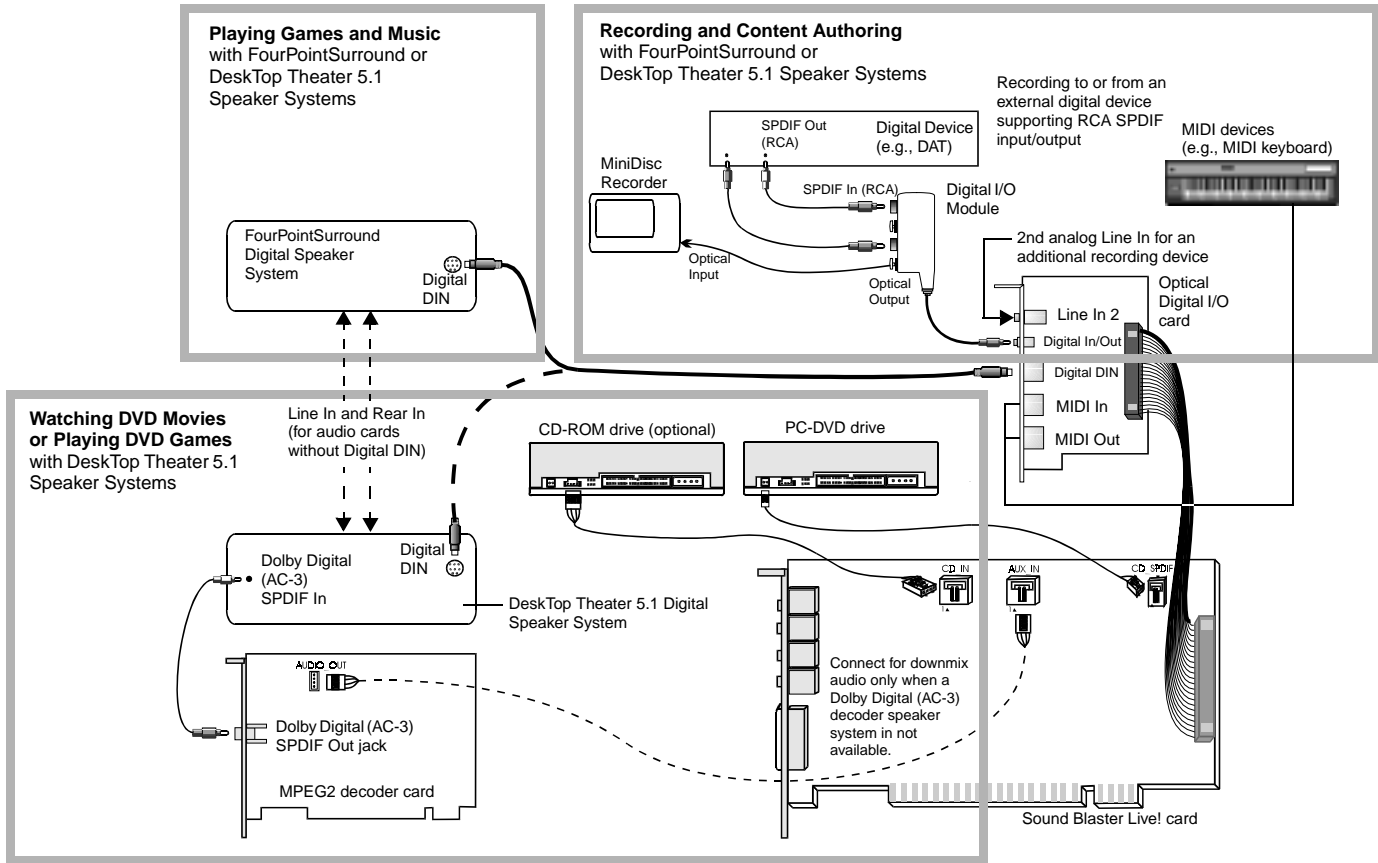

Figure 3: Recommended connection and usage examples.

General Specifications

This section lists the general specifications of your Optical Digital I/O card and Digital I/O Module.

Optical Digital I/O card

Input/Output Terminals

- Second analog Line input jack
- Shared Digital I/O jack for connection to Digital I/O Module
- Digital DIN connector
- MIDI In DIN connector
- MIDI Out DIN connector

Input Sampling Rate

- 32 kHz, 44.1 kHz and 48 kHz

Output Sampling Rate

- 48 kHz

Digital I/O Module

Input/Output Terminals

- Coaxial (RCA) SPDIF input jack
- Optical SPDIF input jack
- Coaxial (RCA) SPDIF output jack
- Optical SPDIF output jack

Declaration of Conformity

According to the FCC96 208 and ET95-19 documents,

Name: *Creative Labs Inc.*

Address: *1901 McCarthy
Boulevard
Milpitas, CA 95035
United States
Tel: (408) 428-6600*

declares under its sole responsibility that the product

Trade Name: *Creative Labs*

Model Number: *CT4770/CT4800*

has been tested according to the FCC / CISPR22/85 requirements for Class B devices and found compliant with the following standards:

EMI/EMC:ANSI C63.4 1992, FCC Part 15 Subpart B

This device complies with part 15 of the FCC Rules.

Operation is subject to the following two conditions:

1. This device may not cause harmful interference, and
2. This device must accept any interference received, including interference that may cause undesirable operation.

Ce matériel est conforme à la section 15 des règles FCC.

Son Fonctionnement est soumis aux deux conditions suivantes:

1. Le matériel ne peut être source D'interférences et
2. Doit accepter toutes les interférences reçues, Y compris celles pouvant provoquer un fonctionnement indésirable.

Supplementary Information:

CT4770 is an add-on daughter board for CT4760 card. It provides connectivity to MIDI In/Out and Digital DIN.

CT4800 is a digital module. It supports Optical/RCA SPDIF In/Out signal when connected with CT4770 board.

*Compliance Manager
Creative Labs, Inc.
March 16, 1999*



Information in this document is subject to change without notice and does not represent a commitment on the part of Creative Technology Ltd. No part of this manual may be reproduced or transmitted in any form or by any means, electronic or mechanical, including photocopying and recording, for any purpose without the written permission of Creative Technology Ltd. The software described in this document is furnished under a license agreement and may be used or copied only in accordance with the terms of the license agreement. It is against the law to copy the software on any other medium except as specifically allowed in the license agreement. The licensee may make one copy of the software for backup purposes.

Copyright © 1998-1999 by Creative Technology Ltd. All rights reserved.

Version 1.0

May 1999

Sound Blaster and Blaster are registered trademarks, and the Sound Blaster Live! logo, the Sound Blaster PCI logo, PC-DVD, E-mu Environmental Modeling, Environmental Audio, and Creative Multi Speaker Surround, are trademarks of Creative Technology Ltd. in the United States and/or other countries. E-Mu and SoundFont are registered trademarks of E-mu Systems, Inc.. SoundWorks is a registered trademark, and MicroWorks, DeskTop Theater, PCWorks, and FourPointSurround are trademarks of Cambridge SoundWorks, Inc.. Microsoft, MS-DOS, and Windows are registered trademarks of Microsoft Corporation. All other products are trademarks or registered trademarks of their respective owners.

This product is covered by one or more of the following U.S. patents:

4,506,579; 4,699,038; 4,987,600; 5,013,105; 5,072,645; 5,111,727; 5,144,676; 5,170,369; 5,248,845; 5,298,671; 5,303,309; 5,317,104; 5,342,990; 5,430,244; 5,524,074; 5,698,803; 5,698,807; 5,748,747; 5,763,800; 5,790,837.